

**JAL-KG4-E2006B V3.0****OmniVision OV12830 MIPI Interface Auto-foco 12MP Módulo de Câmera**

<b>Módulo de câmara No.</b>	<b>JAL-KG4-E2006B V3.0</b>
<b>Sensor de imagem</b>	OV12830
<b>EFL</b>	3.37 mm
<b>F.NO</b>	2.8
<b>Pixel</b>	4256 x 3016
<b>Ângulo de visão</b>	72°
<b>Tipo de lente</b>	1/3.2 polegada
<b>Dimensões da lente</b>	8.50 x 8.50 x 5.60 mm
<b>Tamanho do Módulo</b>	16.25 x 9.00 mm
<b>Tipo de Módulo</b>	Auto-foco
<b>Interface</b>	MIPI

**Acasalamento Parte conector No. 24-5804-030-000-829**

Conector de acoplamento na placa principal. Vendido separadamente.

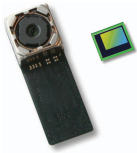

# OV12830 12.7-megapixel product brief



## Full Resolution 12.7-Megapixel High-Speed Photography and 1080p/60 HD Video for Smartphones and Tablets



available in a lead-free package

OmniVision's OV12830 is a 12.7-megapixel CameraChip™ sensor designed to meet the high quality image and video recording standards of the next generation high-end smartphones and tablets. In addition to capturing 1080p/60 high-definition (HD) video, the sensor is capable of capturing full resolution 12.7-megapixel images at 24 frames per second (fps), enabling high-speed photography.

The OV12830 utilizes 1.1-micron OmniBSI-2™ pixel architecture to enable an active array of 4224 x 3000 pixels (12.7-megapixel) operating at 24 fps, which minimizes shutter lag from shot-to-shot. An on-chip RAW scalar allows the sensor to capture 10-megapixel resolution video in a 16:9 aspect ratio (4224 x 2376 pixels) at 30 fps, while maintaining full field of view. Furthermore, the 1/3.2-inch OV12830 is capable of

capturing full 1080p HD video at 60 fps with additional pixels for EIS. The OV12830 provides alternate row output from full-resolution at two different exposures, enabling high-dynamic range (HDR) still or video recording.

The sensor comes in die format with industry standard 4-lane MIPI interface connectivity. The sensor offers programmable controls for frame rate, mirror and flip, cropping, windowing and scaling, as well as support for horizontal and vertical sub-sampling. All required image quality controls, including defective pixel correction, lens shading correction and black level calibration are programmable through the SCCB interface.

Find out more at [www.ovt.com](http://www.ovt.com).



## Applications

- Cellular and Mobile Phones
- Tablets
- Digital Still and Video Cameras (DSC/DVC)
- PC Multimedia
- 3D Cameras

## Product Features

- OmniBSI-2™ pixel technology
- programmable controls for frame rate, mirror and flip, cropping, windowing, and scaling
- image quality controls: defect pixel correction, lens shading correction, and black level calibration
- supports horizontal and vertical subsampling
- supports 2x2 binning, re-sampling filter
- support for image sizes:
  - 12.7MP (4224x3000)
  - 12MP (4000x3000)
  - 10MP (4224x2376)
  - EIS 1080p (2112x1188)
  - EIS 720p (1536x864)
- support for output formats: 10-bit RAW RGB and DPCM 10-8 compression
- fast mode switching
- supports 3D applications
- programmable I/O drive capability
- on chip RAW scalar
- up to 4-lane MIPI serial output interface
- embedded 4K bits one-time programmable (OTP) memory for part identification, etc...
- standard serial SCCB interface
- built-in temperature sensor
- HDR via alternative row exposure
- two on-chip phase lock loop (PLL)

# OV12830



## Ordering Information

- OV12830-G04A**  
(color, chip probing, 200 μm backgrounding, reconstructed wafer with good die)

## Product Specifications

- active array size:** 4256 x 3016
- power supply:**
  - analog: 2.6 - 3.0V
  - core: 1.27 - 1.32V for up to 1 Gbps/lane MIPI
  - I/O: 1.7 - 3.0V
- temperature range:**
  - operating: -30°C to 70°C junction temperature
  - stable image: 0°C to 50°C junction temperature
- output formats:** RAW RGB data
- lens size:** 1/3.2"
- lens chief ray angle:** 30.3° non-linear
- input clock frequency:** 6 - 27 MHz
- dynamic range:** 72 dB @ 8x gain
- maximum image transfer rate:**
  - 12.7MP: 24 fps
  - 12MP: 24 fps
  - 10MP (4224x2376): 30 fps
  - EIS1080p: 60 fps
  - EIS720p: 60 fps
  - VGA: 120 fps
- scan mode:** progressive
- pixel size:** 1.1 μm x 1.1 μm
- image area:** 4681.6 μm x 3317.6 μm
- die dimensions:** 6300 μm x 5570 μm

## Functional Block Diagram

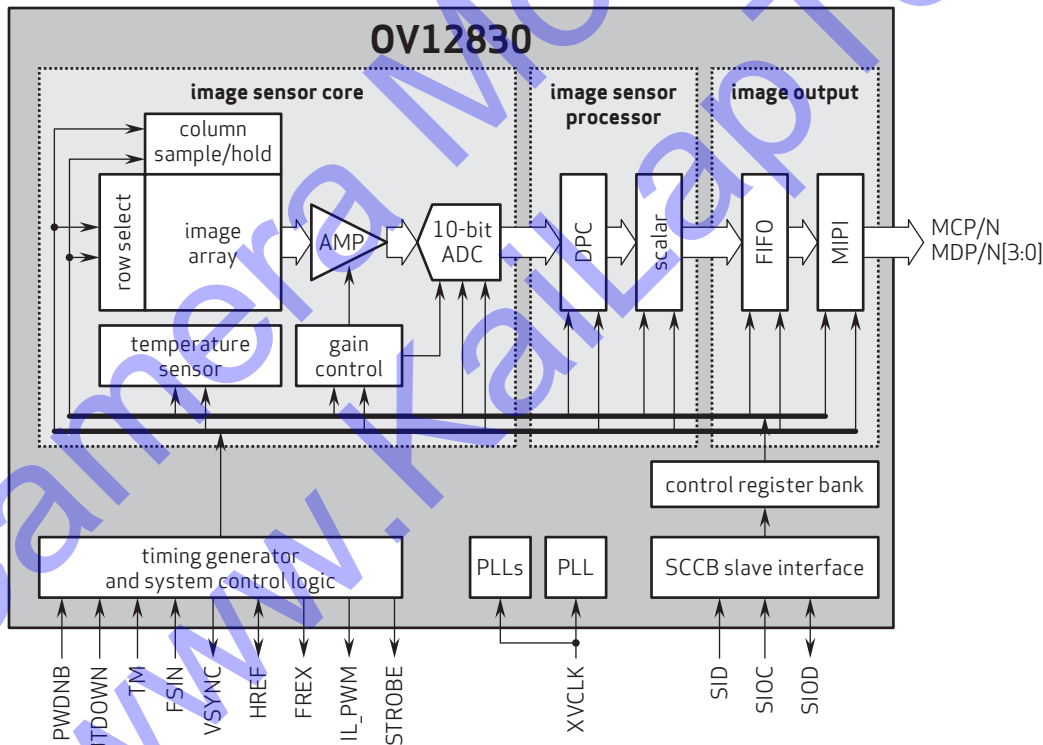

4275 Burton Drive  
Santa Clara, CA 95054  
USA

Tel: + 1 408 567 3000  
Fax: + 1 408 567 3001  
www.ovt.com

OmniVision reserves the right to make changes to their products or to discontinue any product or service without further notice. OmniVision, the OmniVision logo and OmniPixel are registered trademarks of OmniVision Technologies, Inc. OmniBSI-2 is a trademark of OmniVision Technologies, Inc. All other trademarks are the property of their respective owners.

